

REVISIONS				
ZONE	REV	DESCRIPTION	DATE	APPROVED
	000	ORIGINAL ISSUE	6-4-13	GCP

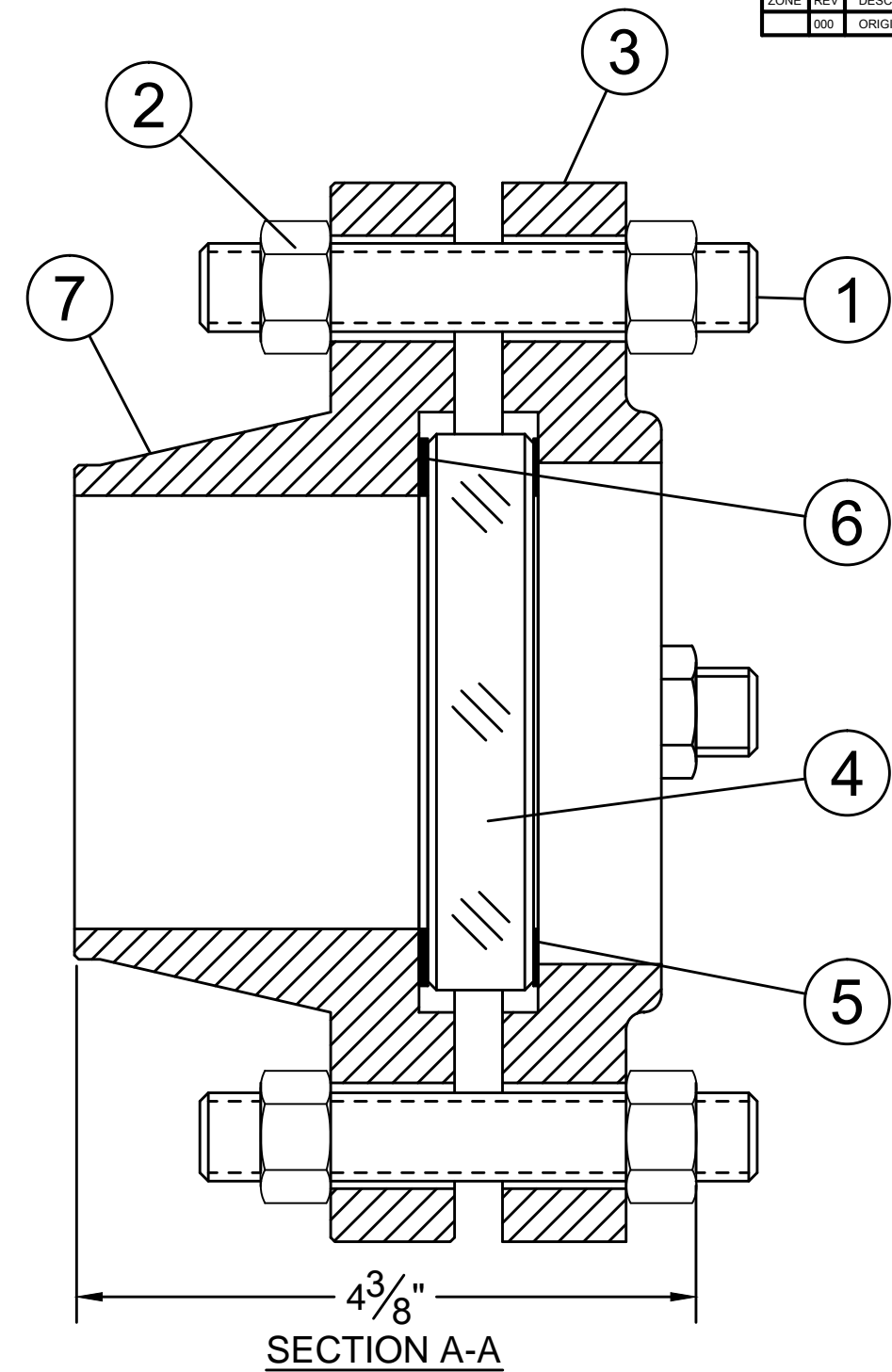
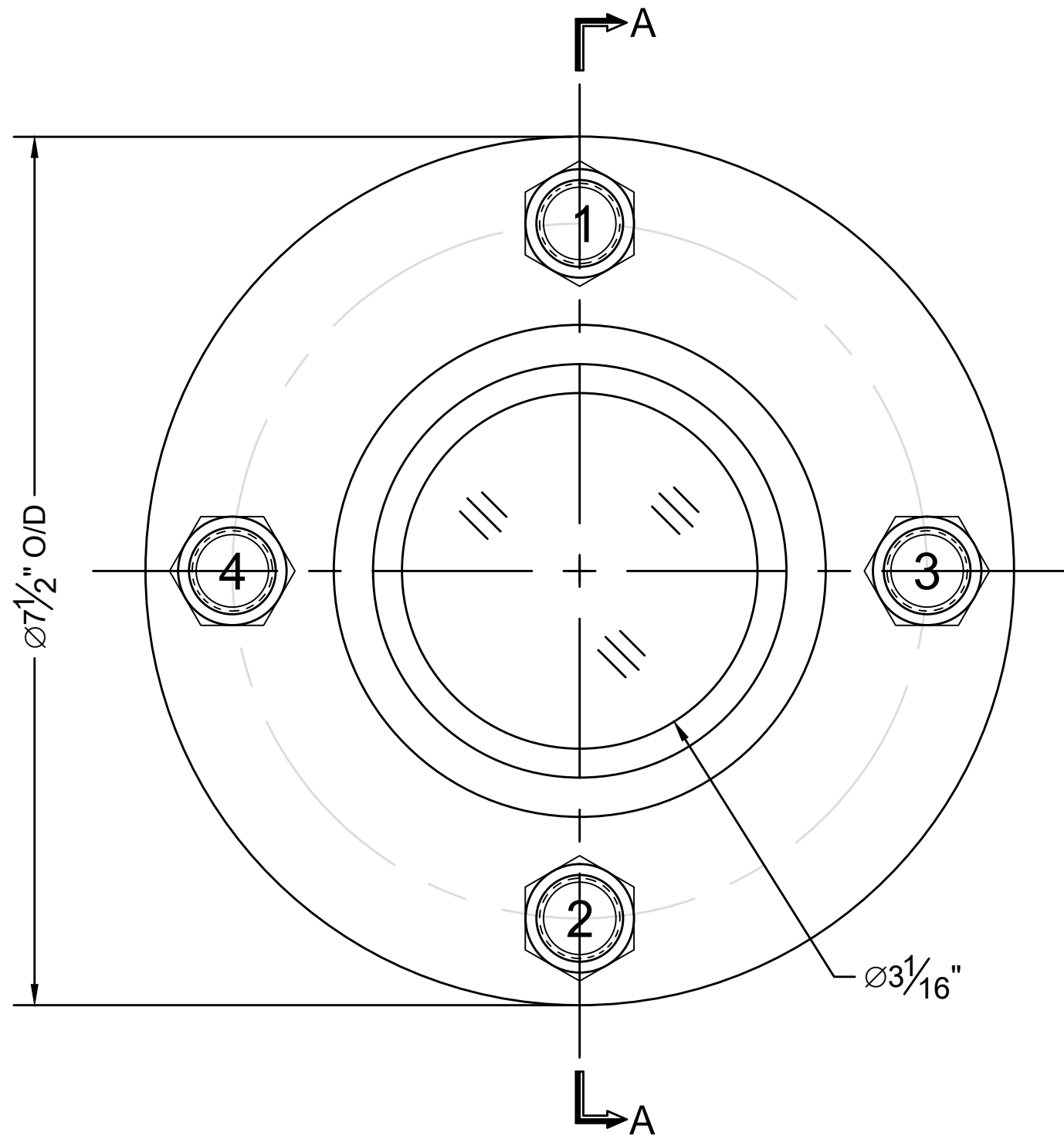

QTY	SYM	DESCRIPTION
1	7	WELD NECK FLG
1	6	SEAL GASKET
1	5	CUSHION
1	4	LENS
1	3	LENS RETAINER
8	2	HEX NUT
4	1	THREADED STUD

BILL OF MATERIAL

Notes:

- [1] Certified Mill Test Reports are included for Lens Retainer [SYM#3] and Weld Pad [SYM#7].
- [2] "Certificate of Conformance" stating compliance with drawing and sales order documents available upon request at time of order.
- [3] It is the vessel fabricator's responsibility to verify that the weld pad offers sufficient reinforcement for the particular application.
- [4] Read and Understand Installation and maintenance manual before installation or service. Tighten fasteners in small increments to the values shown below following torque sequence shown do not exceed a maximum 3ft/lbs difference at anytime.

MODEL#	MAX. PRESSURE	ELASTOMERS	EXPANDED PTFE	GRAPHITE
3"NW-BW	150PS/FV	13 FT/LB	20 FT/LB	17 FT/LB

UNLESS OTHERWISE NOTED:  
 DIMENSIONS ARE IN INCHES.  
 DIMENSIONS ARE SYMMETRICAL ABOUT CENTERLINES.  
 BREAK CORNERS, REMOVE BURRS.  
 CASTING FILLET RADII:  $\frac{1}{8}$ "R  
 CAST CORER RADII:  $\frac{1}{16}$ "R

MACHINING TOLERANCES:  
 FRACTIONS:  $+\frac{1}{64}$   
 DECIMALS:  $\pm 0.010$   
 ANGLES:  $+\frac{1}{2}$  deg  
 FILLET RADII:  $\frac{1}{32}$ "R  
 MACHINED FINISH: RA 125u in  
 $\text{Ⓢ}$   $\text{Ⓣ}$   $\text{Ⓚ}$   $\text{Ⓛ}$   $\text{Ⓜ}$  WITHIN  $\frac{1}{64}$  FIM

ASME CODE CALCULATIONS AND ANY RESULTING ADDITIONAL MATERIAL NEEDED TO REINFORCE SIGHT GLASS OPENING TO MEET ASME CODE IS THE RESPONSIBILITY OF THE VESSEL MANUFACTURER.

THIS DRAWING IS THE SOLE PROPERTY OF THE J.G. PAPAILIAS COMPANY, INC AND NEITHER THE DOCUMENT NOR THE INFORMATION CONTAINED HEREIN SHALL BE COPIED, REPRODUCED, DISCLOSED OR TRANSFERRED EXCEPT AS AUTHORIZED IN WRITING BY AN OFFICER OF THE J.G. PAPAILIAS CO., INC.

Rating:  
 1. Max. Temperature: Dependant on glass and gasket selection.  
 2. Max. Pressure: 150PSI/FV

DRAWN:	GCP	9/12/14
CHECKED:	GCP	9/12/14
APPROVED:	GCP	9/12/14



MODEL#: 3"NW-BW  
 3" 150# WELD NECK STYLE SIGHT GLASS

SIZE	CAGE CODE	DRAWING NUMBER	REV
B	12740	01C048	0

SCALE: 3/4	EST. WEIGHT: 36 LB [16 KG]	SHEET: 1 OF 1
------------	----------------------------	---------------